

Brosses circulaires sur tige



1



2

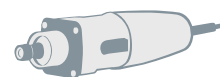

Brosses circulaires sur tige Ø 6

D	A	H	tr/min max.	Cond.	1 2			
					STA 0,15 Code article	STA 0,20 Code article	STA 0,30 Code article	STA 0,50 Code article
20	6	3	20.000	10	<i>411.132</i>	411.142		
30	6	6	20.000	10	413.132	413.142	413.162	
30	9	6	20.000	10	<i>413.133</i>	413.143	413.163	
40	9	9	18.000	10	414.132	414.142	414.162	414.192
40	12	9	18.000	10	<i>414.133</i>	414.143	414.163	<i>414.193</i>
50	11	12	15.000	10	<i>415.132</i>	415.142	415.162	415.192
50	15	12	15.000	10	415.133	415.143	415.163	<i>415.193</i>
60	13	17	15.000	10	<i>416.132</i>	416.142	416.162	sur demande
60	18	17	15.000	10	416.133	416.143	416.163	<i>416.193</i>
70	9	19	15.000	10	<i>417.132</i>	417.142	417.162	417.192
70	13	19	15.000	10	417.133	417.143	417.163	sur demande
80	9	20	15.000	10	sur demande	418.142	418.162	<i>418.192</i>
80	13	20	15.000	10	sur demande	418.143	418.163	sur demande
100	14	25	12.000	10		41Z.143	41Z.163	
100	19	25	12.000	10		41Z.144	41Z.164	

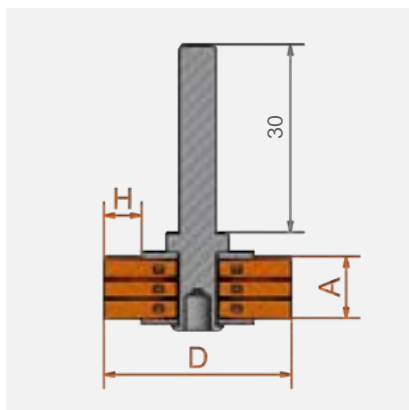

Articles imprimés en gras disponibles sur stock.
Pour les articles imprimés en italique, respectez la valeur minimale de la commande (v. page 164).

STA = Fil d'acier, ondulé

ROF = Fil inoxydable, ondulé

RO4 = Fil inoxydable, droit, 1.4401